

Blank Module
HM800

Manual

English





HAMEG[®]
Instruments

DECLARATION OF CONFORMITY

Manufacturer HAMEG Instruments GmbH
Industriestraße 6
D-63533 Mainhausen

The HAMEG Instruments GmbH herewith declares conformity of the product

Product name: Blank Module
Type: HM800
with: HM8001-2
Options: -

with applicable regulations
EMC Directive 89/336/EEC amended by
91/263/EWG, 92/31/EEC

Low-Voltage Equipment Directive 73/23/EEC
amended by 93/68/EEC

Harmonized standards applied

Safety
EN 61010-1:2001 / (IEC 61010-1:2001)
Overvoltage category: II
Degree of pollution: 2

Electromagnetic compatibility
EN 61326-1/A1
Radiation: table 4; Class B
Immunity: table A1

EN 61000-3-2/A14
Harmonic current emissions: Class D

EN 61000-3-3
Voltage fluctuations and flicker

Date: 22.07.2004

Signature

Manuel Roth
Manager

General information regarding the CE marking

HAMEG instruments fulfill the regulations of the EMC directive. The conformity test made by HAMEG is based on the actual generic and product standards. In cases where different limit values are applicable, HAMEG applies the strictest standard. For emission the limits for residential, commercial and light industry are applied. Regarding the immunity (susceptibility) the limits for industrial environment have been used.

The measuring and data lines of the instrument have much influence on emission and immunity and therefore on meeting the acceptance limits. For different applications the lines and/or cables used may be different. For measurement operation the following hints and conditions regarding emission and immunity should be observed:

1. Data cables

For the connection between instruments resp. their interfaces and external devices, (computer, printer etc.) sufficiently screened cables must be used.

Maximum cable length of data lines must not exceed 3 m. The manual may specify shorter lengths. If several interface connectors are provided only one of them may be used at any time.

Basically interconnections must have a double screening. For IEEE-bus purposes the double screened cable HZ72 from HAMEG is suitable.

2. Signal cables

Basically test leads for signal interconnection between test point and instrument should be as short as possible. Without instruction in the manual for a shorter length, signal lines must be less than 3 meters long.

Signal lines must be screened (coaxial cable - RG58/U). A proper ground connection is required. In combination with signal generators double screened cables (RG223/U, RG214/U) must be used.

3. Influence on measuring instruments.

In the presence of strong high frequency electric or magnetic fields, even with careful setup of the measuring equipment an influence can not be excluded.

This will not cause damage or put the instrument out of operation. Small deviations of the measuring value (reading) exceeding the instrument's specifications may result from such conditions in some cases.

HAMEG Instruments GmbH

Declaration of conformity	2
General information regarding the CE marking	2
Blank Module HM800	4
Important hints	5
Safety	5
Operating conditions	5
Warranty and Repair	5
Maintenance	6
Operation of the blank module	6
Interface board for HM800	7
HM8001-2 Interface Specification	8

Blank Module HM800



Mainframe HM8001-2
required for operation



Open blank module



- ☑ Module for customized instrument construction
- ☑ Guide rails for mounting circuit boards at 4 different levels
- ☑ Plastic front panel for easy processing
- ☑ Power is supplied by the mainframe HM8001-2
- ☑ Available supply voltages, load capability
see datasheet of HM800

Important hints

The operator is requested to read the following instructions and those of the mainframe HM8001-2 carefully, to avoid any operating errors and mistakes and in order to become acquainted with the module.

After unpacking the blank module, check for any mechanical damage or loose parts inside. Should there be any transportation damage, inform the supplier immediately and do not put the module into operation. This plug-in module is primarily intended for use in conjunction with the mainframe HM8001-2. When incorporating it into other systems, the module should only be operated with the specified supply voltages.

Safety

This instrument has been designed and tested in accordance with IEC Publication 1010-1, Safety requirements for electrical equipment for measurement, control, and laboratory use. It corresponds as well to the CENELEC regulations EN 61010-1. All case and chassis parts are connected to the safety earth conductor. Corresponding to Safety Class 1 regulations (three-conductor AC power cable). Without an isolating transformer, the instrument's power cable must be plugged into an approved three-contact electrical outlet, which meets International Electrotechnical Commission (IEC) safety standards.

Warning!

Any interruption of the protective conductor inside or outside the instrument or disconnection of the protective earth terminal is likely to render the instrument dangerous. Intentional interruption is prohibited.

The instrument must be disconnected and secured against unintentional operation if there is any suggestion that safe operation is not possible.

This may occur:

- if the instrument shows visible damage,
- if the instrument has loose parts.
- if the instrument does not function,
- after long storage under unfavourable circumstances (e.g. outdoors or in moist environments),

- after excessive transportation stress (e.g. in poor packaging).

When removing or replacing the metal case, the instrument must be completely disconnected from the mains supply. If any measurement or calibration procedures are necessary on the opened-up instrument, these must only be carried out by qualified personnel acquainted with the danger involved.

Symbols marked on equipment



ATTENTION refer to manual.



DANGER! High voltage.



Protective ground (earth) terminal.

Operating conditions

The ambient temperature range during operation should be between +5°C and +40°C and should not exceed -20°C or +70°C during transport or storage. The operational position is optional, however, the ventilation holes on the HM8001-2 and on the plug-in modules must not be obstructed.

Warranty and Repair

HAMEG instruments are subjected to a strict quality control. Prior to leaving the factory, each instrument is burnt-in for 10 hours. By intermittent operation during this period almost all defects are detected. Following the burn-in, each instrument is tested for function and quality, the specifications are checked in all operating modes; the test gear is calibrated to national standards.

The warranty standards applicable are those of the country in which the instrument was sold. Reclamations should be directed to the dealer.

Only valid in EU countries

In order to speed reclamations customers in EU countries may also contact HAMEG directly. Also, after the warranty expired, the HAMEG service will be at your disposal for any repairs.

Return material authorization (RMA):

Prior to returning an instrument to HAMEG ask for a RMA number either by internet (<http://www.hameg.com>) or fax. If you do not have an original shipping carton, you may obtain one by calling the HAMEG service dept (+49-6182-800-500) or by sending an email to service@hameg.com.

Maintenance

The most important characteristics of the instruments should be periodically checked according to the instructions provided in the sections "Operational check and alignment procedure". To obtain the normal operating temperature, the mainframe with inserted module should be turned on at least 60 minutes before starting the test. The specified alignment procedure should be strictly observed. When removing the case detach mains/line cord and any other connected cables from case of the mainframe HM8001-2. Remove both screws on rear panel and, holding case firmly in place, pull chassis forward out of case. When later replacing the case, care should be taken to ensure that it properly fits under the edges of the front and rear frames. After removal of the two screws at the rear of the module, both chassis covers can be lifted. When reclosing the module, care should be taken that the guides engage correctly with the front chassis.

Operation of the blank module

Provided that all hints given in the operating instructions of the mainframe HM8001-2 were followed especially for the selection of the correct mains voltage start of operation consists practically of inserting the module into the right or left opening of the mainframe. The following pre-cautions should be observed:

Before exchanging the module, the mainframe must be switched off. A small circle (o) is now revealed on the red power button in the front centre of the mainframe.

If the BNC sockets at the rear panel of the HM8001-2 unit were in use before, the BNC cables should be disconnected from the basic unit for safety reasons. Slide in the new module until the end position is reached.

Before being locked in place, the cabinet of the instrument is not connected to the protective earth terminal (banana plug above the mainframe multipoint connector). In this case, no test signal must be applied to the input terminals of the module.

Generally, the HM8001-2 set must be turned on and in full operating condition, before applying any test signal. If a failure of the measuring equipment is detected, no further measurements should be performed. Before switching off the unit or exchanging a module, the instrument must be disconnected from the test circuit.

Interface board for HM800

The interface board HM800 permits the setting of 3 voltages. One of these voltages is fixed to +5V. The others can be programmed from 5.2V to +20.0V due to the two resistors. *)

The Resistor R402 sets V_A voltage. Resistor R401 sets V_B voltage. The relation between the value of the resistors and the output voltage is defined by the following formula:

$$R_{401(2)} = \frac{18.8}{V_{A(B)} - 5.2}$$

Without any resistance, the output voltage amounts 5.2V. The following table shows the resistance values for some common voltages.

VA (3-4 of CN401)	R401
VB (5-6 of CN401)	R402
5.2V	No resistor
10V	3.92 k Ω
12V	2.80 k Ω
15V	1.92 k Ω
18V	1.5 k Ω
20V	1.3 k Ω

All of the 3 voltages are isolated from each other. One of these voltages can use capacitors between outputs and ground for EMC (C401 to C406, 100nF X7R 100V). C407 and C408 are used for stability of the regulation (1nF ceramic capacitors).

Two straps must be soldered as shown in the figure on the next page.

*) For detailed information regarding the connection of the resistors, please refer also to figure "HM8001-2 Interface specification" on page 8.

HM8001-2 Interface Specification

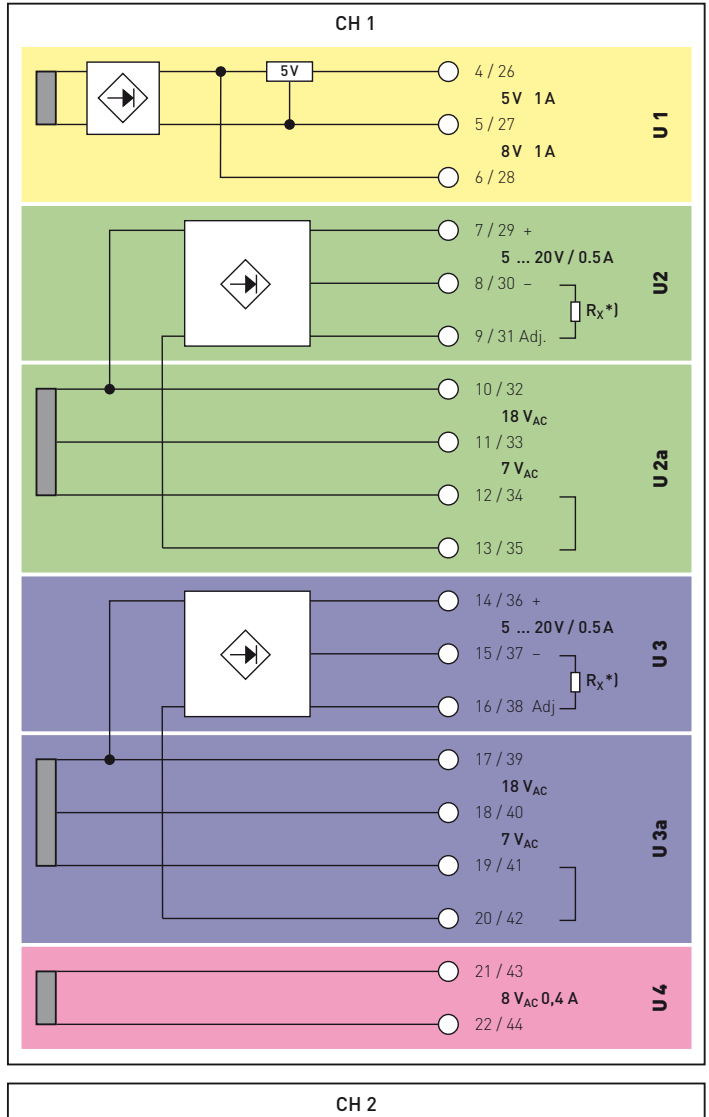
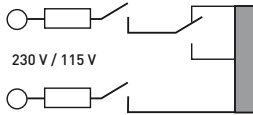
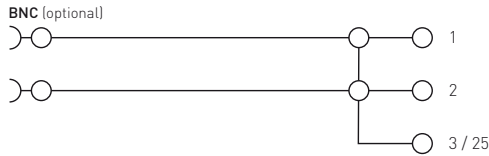

*) R_x : for the resistance values please refer to tables on page 7 and 9

HM8001-2 Interface Specification

Connector-Pin			Description	Voltage at	
Bottom	Top	I_{min}		I_{max}	
BNC	1	23	1 st BNC- resp. 4 th BNC-connector (Only PIN1; PIN 23 NC)		
	2	24	2 nd BNC- resp. 3 rd BNC-connector (Only PIN2; PIN 24 NC)		
	3	25	GND-connection of BNC-connector 1 + 2 (floating)		
U1	4	26	+5V regulated. Reference PIN 5 + 27; $1 A_{max}$ [Σ [5V, 8V]]	5.0V	
	5	27	GND [5V + 8V] (floating)		0.0V
	6	28	+8V not regulated. Reference PIN 5 + 27; $1 A_{max}$ [Σ [5V, 8V]]	14.6V	
U2	7	29	+5...20V regulated. Reference PIN 8 + 30; PIN 11 + 13 need to be connected. $0.5 A_{max}$	16.9V	16.9V *)
	8	30	GND +5...20V (Potential 2)		
	9	31	Control input; $R_{Ci} = 18.8 / (U_a - 5.2V)$ ($R_{Ci} = R$ between PIN 8 + 9)	1.62k Ω *)	
U2a	10	32	Between Pin 10 + 11; $18 V_{AC} 0.8 A_{max}$ (Potential 2)	20.7V	19.2V
	11	33	Between Pin 11 + 12; $7 V_{AC} 0.8 A_{max}$ (Potential 2)	7.0V	6.6V
	12	34	Between Pin 10 + 12 $25 V_{AC} 0.8 A_{max}$ (Potential 2)	27.7V	
	13	35	Supply of U2 (U2a not used) (connect PIN 11 + 13)		
U3	14	36	+5...20V regulated. Reference PIN 15 + 37. PIN 18 + 20 need to be connected. $0.5 A_{max}$	16.6V	16.6V *)
	15	37	GND +5...20V (Potential 3)		
	16	38	Control input; $R_{Ci} = 18.8 / (U_a - 5.2V)$ ($R_s = R$ between PIN 15 + 16)	1.62k Ω *)	
U3a	17	39	Between Pin 17 + 18; $18 V_{AC} 0.8 A_{max}$ (Potential 3)	20.6V	19.3V
	18	40	Between Pin 18 + 19; $7 V_{AC} 0.8 A_{max}$ (Potential 3)	7.0V	6.6V
	19	41	Between Pin 17 + 19; $25 V_{AC} 0.8 A_{max}$ (Potential 3)	27.6V	
	20	42	Supply of U3 (U3a not used) (connect PIN 18 + 20)		
U4	21	43	$8 V_{AC} 0.4 A_{max}$ (floating)	9.3V	8.8V
	22	44	$8 V_{AC} 0.4 A_{max}$		

*) The voltages shown in line 7 and 14 are calculated based on the resistance values chosen in line 9 and 16.

The provided values are taken from a series instrument and are for reference only. The values may deviate up to 5%.

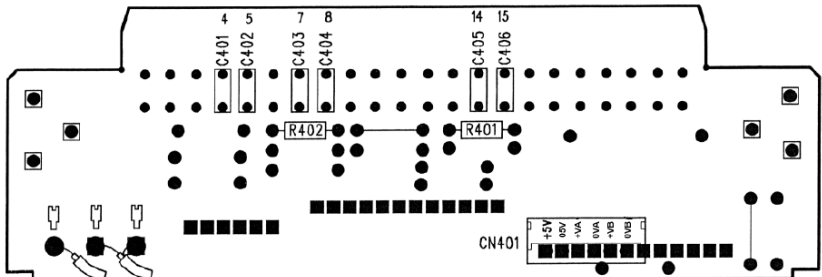

Oscilloscopes



Spectrum Analyzer



Power Supplies



Modular System
Series 8000



Programmable Instruments
Series 8100



authorized dealer

www.hameg.com



44-0800-00E0

Subject to change without notice
44-0800-00E0 (1) 08042009
© HAMEG Instruments GmbH
A Rohde & Schwarz Company



DQS-Certification: DIN EN ISO 9001:2000
Reg.-Nr.: DE-071040 QM

HAMEG Instruments GmbH
Industriestraße 6
D-63533 Mainhausen
Tel +49 (0) 61 82 800-0
Fax +49 (0) 61 82 800-100
sales@hameg.com